

# Inquiry Sheet for Step Drills

L
L2
L3
SL
S
D
d
W
R / W2
L4 max

- Through Coolant
- Right Hand Rotation
- Left Hand Rotation
- PCD Tipped
- Diamond Coated
- Non-Stick Coated
- Solid Carbide

## Machine Data

$n$  max (rpm max) \_\_\_\_\_ 1/min

$vf$  max (feed rate) \_\_\_\_\_ in/min

Manual Operation  CNC Operation

How are you holding the drill? \_\_\_\_\_

## Workpiece

Blind Hole  Through Hole

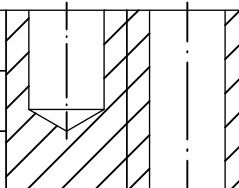
Stack 1	_____ in	fabric type 1	
Stack 2	_____ in	fabric type 2	
Stack 3	_____ in	fabric type 3	

Drilling Depth \_\_\_\_\_ in  
 Tolerance Ø \_\_\_\_\_ in

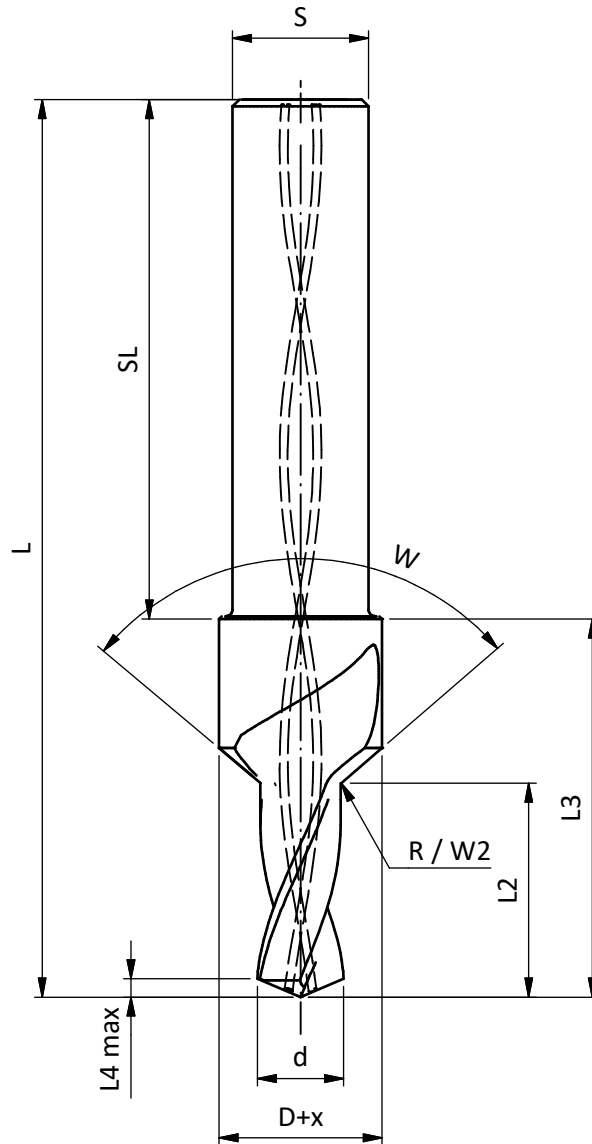

Company Name
Project Number
Date
Notes
Number of parts /run
Annual Demand
Current Process

